

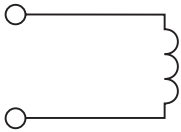

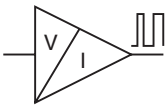
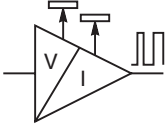

	SERIES	DESCRIPTION	PAGE NO.	
	<b>SUPER COILS</b>			
	CC	1/2" Solenoid Tubes	CE3-CE4	
	CA	5/8" Solenoid Tubes	CE5-CE6	
	<b>STANDARD COILS</b>			
	Unicoil	1/2" Solenoid Tubes	CE7-CE8	
	Unicoil	5/8" Solenoid Tubes	CE9-CE10	
	DS	1/2" Solenoid Tubes	CE11-CE12	
	DS	5/8" Solenoid Tubes	CE13-CE14	
	DS	1" Solenoid Tubes	CE15	
		<b>ELECTRONICS</b>		
XPRO902		12 VDC PWM Controller, 110Hz, 19W	CE17-CE18	
XPRO932		12 VDC PWM Controller, 110Hz, 30W	CE17-CE18	
XPRO904		24 VDC PWM Controller, 110Hz, 19W	CE17-CE18	
XPRO934		24 VDC PWM Controller, 110Hz, 30W	CE17-CE18	
		XPRO902d	12 VDC PWM Controller, 95-230Hz, 19W	CE19-CE20
		XPRO932d	12 VDC PWM Controller, 95-230Hz, 30W	CE19-CE20
		XPRO904d	24 VDC PWM Controller, 95-230Hz, 19W	CE19-CE20
		XPRO934d	24 VDC PWM Controller, 95-230Hz, 30W	CE19-CE20
		XPRO902rid	12 VDC PWM Controller, 95-230Hz, 19W, Multi-adj.	CE21-CE22
		XPRO932rid	12 VDC PWM Controller, 95-230Hz, 30W, Multi-adj.	CE21-CE22
		XPRO904rid	24 VDC PWM Controller, 95-230Hz, 19W, Multi-adj.	CE21-CE22
		XPRO934rid	24 VDC PWM Controller, 95-230Hz, 30W, Multi-adj.	CE21-CE22
		XPRO704	Soft Start Valve Controller, 12/24 VDC	CE23
		XPRO704b	Soft Start and Stop Valve Controller, 12/24 VDC	CE24
	XPRO804	Power Saver Controller, 12/24 VDC PWM	CE25	

<b>CV</b>
Check Valves
<b>SH</b>
Shuttle Valves
<b>LM</b>
Load/Motor Controls
<b>FC</b>
Flow Controls
<b>PC</b>
Pressure Controls
<b>LE</b>
Logic Elements
<b>DC</b>
Directional Controls
<b>MV</b>
Manual Valves
<b>SV</b>
Solenoid Valves
<b>PV</b>
Proportional Valves
<b>CE</b>
Coils & Electronics
<b>BC</b>
Bodies & Cavities
<b>TD</b>
Technical Data

<b>CV</b>	Check Valves
<b>SH</b>	Shuttle Valves
<b>LM</b>	Load/Motor Controls
<b>FC</b>	Flow Controls
<b>PC</b>	Pressure Controls
<b>LE</b>	Logic Elements
<b>DC</b>	Directional Controls
<b>MV</b>	Manual Valves
<b>SV</b>	Solenoid Valves
<b>PV</b>	Proportional Valves
<b>CE</b>	Coils & Electronics
<b>BC</b>	Bodies & Cavities
<b>TD</b>	Technical Data

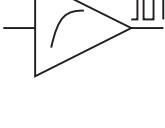
**INTRODUCTION**

This technical tips section is designed to help familiarize you with the Parker line of Coils. In this section we highlight the features and discuss some of the available options. We also use this section to present some common terminology related to coil and coil technology.

# New Parker **SUPER COIL** Now Available!

**Class N Magnetic Wire**  
Internal wires have a class N rating, providing longer life at typical temperatures.

**DC Windings**  
All coils are DC wound. An internal full wave rectifier is added for AC current, eliminating inrush current, and allowing for voltage interchangeability.

**Variety of Terminations**  
Coils are offered in a wide variety of terminations, including integrally molded connectors and voltages to meet your system requirements.

**Rugged Thermoplastic Encapsulation**  
Coil is encased in a thermoplastic polyester resin. This allows for higher temperature exposure and less flexural creep. Also, this resin is resistant to moisture, caustic solutions, and fungus providing protection for coil windings.

**Low Carbon Steel Frame**  
Zinc plated low carbon steel frame surrounds coil, increasing flux density. Low carbon steel provides better magnetic properties and greater permeability.

**Diodes**  
Internally molded diodes are available. Polarity is molded into coil for ease of installation.

**Ribbed Surface**  
External ridges provide a larger coil surface area, which allows for better heat dissipation.



**\*Exceeds IP69k Specifications**

After exhaustive testing, the new Super Coil has clearly distanced itself from the competition. This coil was subjected to the rigors of this environmental standard and the results were excellent. This coil stands up to most rugged of environmental conditions including weather, dust, and extreme temperature variations.

**\*Water Dunk Test Qualified**

The Super Coil was taken to task in a repeated water dunk thermal cycle test program with alternate exposure to high and low temperature, only to perform with outstanding results.

**\*Endurance Tested**

The goal of this test was to cycle the coil to high temperature extremes in order to validate the coils ability to perform in extreme temperature environments.

**\*Water Spray and Chemical Solvent Compatibility**

The Super Coil was subjected to numerous chemical solvents in a rigorous test which established the fact that these coils can withstand harsh and unusual environments. Also, the coils were subjected to a high pressure water spray test. Once again, the Super Coil passed this test.

*\*Deutsch connector required.*

**COMMON OPTIONS**

Below are some of the common options to the Unicoil product offering.

**Continuous Duty:** Parker's standard line of coils are rated for continuous duty operation. This means the coil can be left on continuously without fear of the magnet wire insulation breakdown, when used in standard climate conditions. The Unicoils and Super Coils are made of a high quality Class N magnet wire. This Class N rating signifies the internal wires are rated to 200°C (392°F).

Continuous duty does not mean the coil will have the same amount of power after hours of operation as it had at initial actuation. Coils do heat up during use. This internal heat rise increases the resistance of the coil and thus, decreases the current ( $V = IR$ ). The performance curves presented on the solenoid valve pages are based on a coil at room temperature and 85% of voltage. Thus, when using a valve in continuous duty applications, you may need to derate the performance. In short, the continuous duty rating signifies that while the coil will get hot during use and resistance will increase, it will not generate enough heat to damage the coil.

**Terminations:** Parker offers a wide variety of coil terminations for all coils to meet the demands of your application. Over the years, the dual lead wire and dual spade offerings have been popular due to their ease of installation and availability. In the past few years, the demand for more secure termination connections has increased. In addition, the integral connectors reduce cost and improve integrity by reducing the number of connections. As such, the Amp Junior, Weatherpack, Metri-Pack, and Deutsch have increased in popularity. We offer these connectors on a lead wire coil, as well as an internally molded version of the DIN, Amp Junior, and Metri-Pack coils. If you do not find your desired coil termination in our catalog, contact your factory sales representative. We entertain special requests and have several special terminations not listed in this catalog.

**Current Types:** Both direct current (DC) and alternating current (AC) versions are available for the Parker line of coils. The AC versions are essentially DC coils with a full wave rectifier integrally molded into the coil. The rectifiers are rated for voltage peaks up to 1000 volts maximum. For voltage transients greater than 1000 volts, a Harris Thyrector is recommended. The AC coils operate at 50/60 cycles (Hz). Since the AC versions are rectified

DC coils, there is no inrush current like with "true" AC coils. It also means DC coils and AC coils are interchangeable.

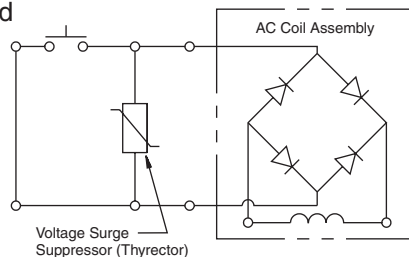

**Voltages:** Parker has a wide selection of coils available to meet your needs. Most coil terminations are available with our standard voltages of 12V and 24V in DC, and 120V and 240V in AC. Voltages 6V, 10V, 18V, 36V, 48V DC and 440V AC are also available for many termination types at a slight premium. Contact your Parker representative should your application call for voltages other than our standard offering.

**Diodes:** The Parker Coils can be ordered with a diode molded internally. Parker Unicoils use a IN5062 diode. The Super Coils use a IN5627 diode. Diodes are sometimes used to protect sensitive, downstream electrical components from potential surges from the coil. By internally molding the diode into the coil, you can reduce the assembly time and cost associated with externally wiring a diode. One should be careful not to switch the polarity ("+" and "-" terminals), when wiring a coil with an internal diode. If these terminals are switched, the first time voltage is applied to the coil; the short circuit will destroy the diode and render the coil use-less. Parker coils with diodes have "+" and "-" molded near the termination outlet to help identify polarity.

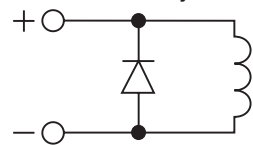

**DIN Connectors:** Parker does offer connectors for use with the DIN style coils. As shown below, the DIN connectors are available in both rectified and non-rectified forms. The cable gland versions can be ordered for type PG9 or PG11.

**Cable Gland**

Type	Non-Rectified	Rectified
PG9	710549-00	712126-01
PG11	710549-01	712126-00

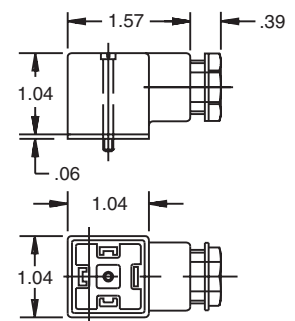

Conduit	Rectified
	712704-00

Conduit	Non-Rectified
	710549-02

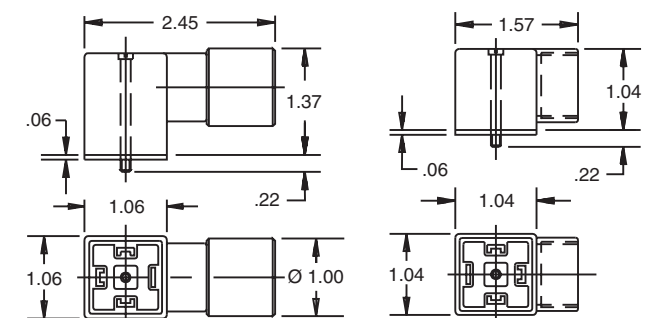

**CV**  
Check Valves

**SH**  
Shuttle Valves

**LM**  
Load/Motor Controls

**FC**  
Flow Controls

**PC**  
Pressure Controls

**LE**  
Logic Elements

**DC**  
Directional Controls

**MV**  
Manual Valves

**SV**  
Solenoid Valves

**PV**  
Proportional Valves

**CE**  
Coils & Electronics

**BC**  
Bodies & Cavities

**TD**  
Technical Data

Technical Information

- CV Check Valves
- SH Shuttle Valves
- LM Load/Motor Controls
- FC Flow Controls
- PC Pressure Controls
- LE Logic Elements
- DC Directional Controls
- MV Manual Valves
- SV Solenoid Valves
- PV Proportional Valves
- CE Coils & Electronics
- BC Bodies & Cavities
- TD Technical Data

Features

- Integral Deutsch connector coil exceeds IP69K standards
- Integral Deutsch connector coil thermal shock dunk test rated
- Integral Amp Jr. coil exceeds IP67 standards for thermal shock, water resistance and "dunk capability"
- Universal 50/60 Hz operation
- Waterproof coil hermetically sealed, requires no O-rings or waterproofing kits
- External plated steel flux-carrying band (unlike encapsulated band) enables coil to withstand severe thermal shocks without cracking
- Symmetrical coil can be reversed without affecting performance

Specifications

<b>Coil Type</b>	<b>S</b> Standard	<b>P</b> Puissant
<b>Nominal Wattage (See Ordering Information For Exact Wattage)</b>	<b>S</b> 14 Watts	<b>P</b> 19 Watts
<b>Duty Cycle</b>	Continuous @ 100% voltage	
<b>Magnetic Wire Insulation Class</b>	'N' Rated at 200°C (392°F)	
<b>Temperature Range</b>	-40°C to +200°C (-40°F to +392°F)	
<b>Temperature Rise At Nominal Voltage And Natural Ventilation</b>	<b>S</b> 75°C (135°F)	<b>P</b> 95°C (172°F)
<b>Dielectric Strength Maximum Current Leakage (Amps)</b>	.0005 In dry lab condition at 1000V AC for 30 seconds	
	.001 After being immersed in 23°C (77°F) water with waterproof connector for 24 hours at 500V AC	
<b>Encapsulating Material</b>	Glass filled rynite	
<b>Color Identification On The Terminal Boss</b>	<b>S</b> Black Ring	<b>P</b> Red Ring
<b>Weight</b>	0.20 kg (0.44 lbs.)	

AC Coil Assembly

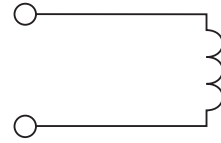
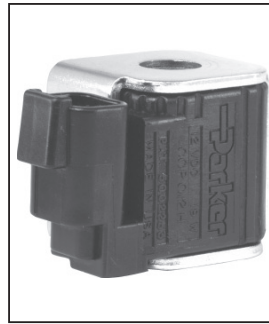
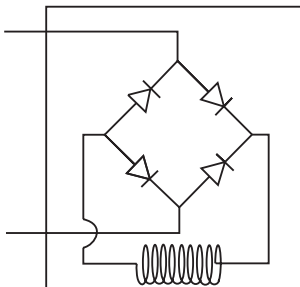

Ordering Information

**CC**

Super Coil  
1/2" I.D.

Wattage

Wattage

Voltage

Voltage

Termination

Termination

Code	Wattage
<b>S</b>	Standard
<b>P</b>	Puissant

Code	Voltage	Watts		Amps		Ohms**	
		S	P	S	P	S	P
<b>010</b>	10 VDC	14	19	1.38	1.90	7.25	5.26
<b>012*</b>	12 VDC	14	19	1.15	1.58	10.43	7.58
<b>018</b>	18 VDC	14	19	0.77	1.06	23.48	17.05
<b>024*</b>	24 VDC	14	19	0.58	0.79	41.74	30.30
<b>048</b>	48 VDC	14	19	0.29	0.40	167.0	121.3
<b>115*</b>	115 VAC	16	19	0.17	0.20	680	576
<b>230</b>	230 VAC	17	22	0.09	0.12	2596	1919

\*Standard \*\*Resistance ±10% at 68°F

Code	Termination
<b>A</b>	Amp Jr. (DC Only)
<b>AD</b>	Amp Jr. with 3 Amp Diode (DC Only)
<b>C</b>	Double Lead Wire with Conduit Connector (AC Only)
<b>D</b>	DIN 43650 (AC or DC, Supplied without DIN Connector)
<b>H</b>	Integral Deutsch
<b>HE</b>	Integral Deutsch with 3 Amp Diode
<b>L</b>	Double Lead (DC Only)
<b>LD</b>	Double Lead with Deutsch Connector DT04-2P-EP04 (DC Only) (Use 'H' series if possible)
<b>LE</b>	Double Lead with 3 Amp Diode (DC Only)
<b>PF</b>	Double Lead Wire with Packard Female Weather Pack Connector 1201 5792 (DC Only)
<b>PM</b>	Double Lead Wire with Packard Male Weather Pack Connector 1201 0973 (DC Only)
<b>S</b>	Double Spade (DC Only)
<b>W</b>	Double Screw (DC only)
<b>WE</b>	Double Screw with 3 Amp Diode (DC Only)
<b>Y</b>	Single Screw (Internally Grounded, DC Only)

Note: Additional voltages and other terminals are available. Some coils are UL approved. For details please consult factory.

DIN Female Mating Connector: See page CL2

Deutsch Mating Connector: # DT06-25

Packard Male Weather Pack Connector: 12010973

Packard Female Weather Pack Connector: 12015792

**Terminal Styles and Dimensions**

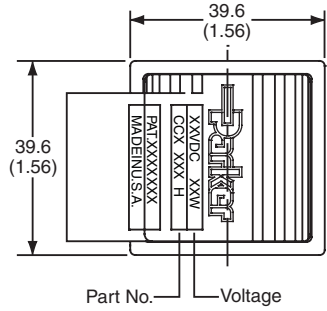
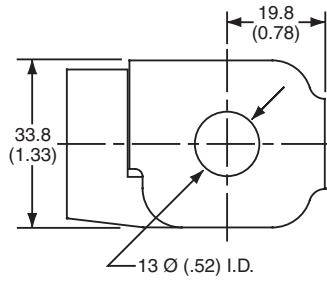

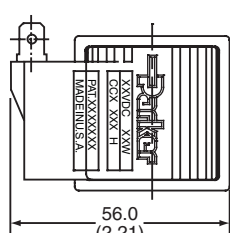
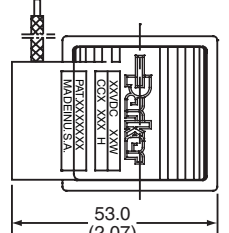
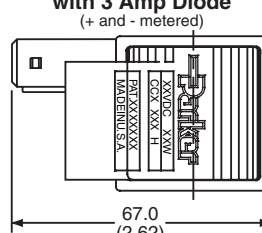
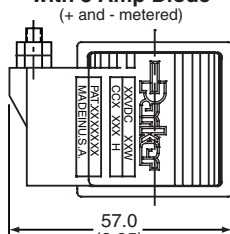
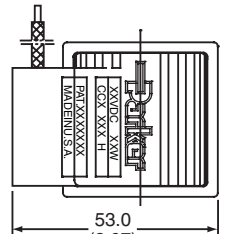
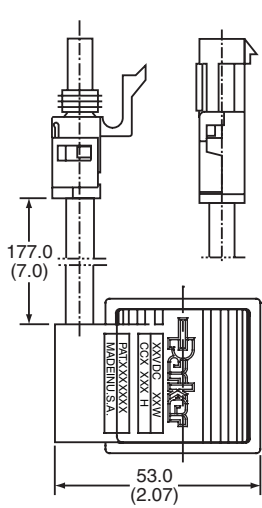
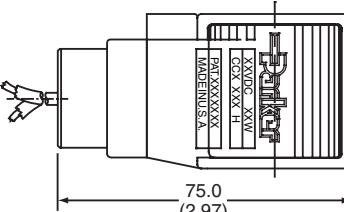
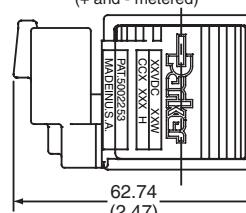
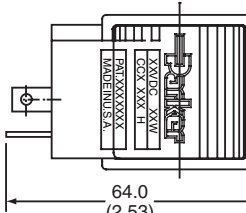
<p><b>S - Double Spade</b></p> 	<p><b>L - Double Lead</b>          18 gauge 457mm 18" long          black color</p> 	<p><b>A - Amp Junior</b>  <b>AD - Amp Junior</b>          with 3 Amp Diode          (+ and - metered)</p> 
<p><b>Y - Single Screw</b>          (Internal ground)          8-32 UNC screw &amp; nut  <b>W - Double Screw</b>          8-32 UNC screw &amp; nut  <b>WE - Double Screw</b>          with 3 Amp Diode          (+ and - metered)</p> 	<p><b>LE - Double Lead</b>          with 3 Amp Diode          18 gauge 457mm (18") long          Red wire positive,          Black wire negative          Diode protection from          positive to negative</p> 	<p><b>PF - Female Packard Connector</b>    <b>PM - Male Packard Connector</b></p> 
<p><b>C - Double Lead</b>          Conduit (1/2" NPTF)          18 gauge 457mm 18" long, black color</p> 	<p><b>H - Integral Deutsch</b>          DT04 - 2P - EP04  <b>HE - Integral Deutsch</b>          with 3 Amp Diode          (+ and - metered)</p> 	<p><b>D - DIN 43650</b>          (ground wire on AC only)</p> 

- NOTES:**
1. The standard A.C. coil includes a molded-in full wave rectifier rated for 800 peak reverse voltage.
  2. All P Puissant (high wattage) coils use a red ring as an indication marker on the terminal boss.

- CV**
- Check Valves
- SH**
- Shuttle Valves
- LM**
- Load/Motor Controls
- FC**
- Flow Controls
- PC**
- Pressure Controls
- LE**
- Logic Elements
- DC**
- Directional Controls
- MV**
- Manual Valves
- SV**
- Solenoid Valves
- PV**
- Proportional Valves
- CE**
- Coils & Electronics
- BC**
- Bodies & Cavities
- TD**
- Technical Data

Technical Information

- CV Check Valves
- SH Shuttle Valves
- LM Load/Motor Controls
- FC Flow Controls
- PC Pressure Controls
- LE Logic Elements
- DC Directional Controls
- MV Manual Valves
- SV Solenoid Valves
- PV Proportional Valves
- CE Coils & Electronics
- BC Bodies & Cavities
- TD Technical Data

Features

- Integral Deutsch connector coil exceeds IP69K standards
- Integral Deutsch connector coil thermal shock dunk test rated
- Integral Amp Jr. coil exceeds IP67 standards for thermal shock, water resistance and "dunk capability"
- Universal 50/60 Hz operation
- Coil hermetically sealed, requires no O-rings or waterproofing kits
- External plated steel flux-carrying band (unlike encapsulated band) enables coil to withstand severe thermal shocks without cracking
- Symmetrical coil can be reversed without affecting performance

Specifications

<b>Coil Type</b>	<b>S</b> Standard	<b>P</b> Puissant
<b>Nominal Wattage (See Ordering Information For Exact Wattage)</b>	<b>S</b> 18 Watts	<b>P</b> 28 Watts
<b>Duty Cycle</b>	Continuous @ 100% voltage	
<b>Magnetic Wire Insulation Class</b>	'N' Rated at 200°C (392°F)	
<b>Temperature Range</b>	-40°C to +200°C (-40°F to +392°F)	
<b>Temperature Rise At Nominal Voltage And Natural Ventilation</b>	<b>S</b> 75°C (135°F)	<b>P</b> 95°C (172°F)
<b>Dielectric Strength Maximum Current Leakage (Amps)</b>	.0005 In dry lab condition at 1000V AC for 30 seconds .001 After being immersed in 23°C (77°F) water with waterproof connector for 24 hours at 500V AC	
<b>Encapsulating Material</b>	Glass filled rynite	
<b>Color Identification On The Terminal Boss</b>	<b>S</b> Black Ring	<b>P</b> Red Ring
<b>Weight</b>	0.29 kg (0.64 lbs.)	

AC Coil Assembly

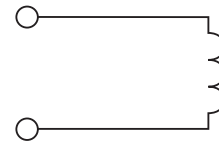
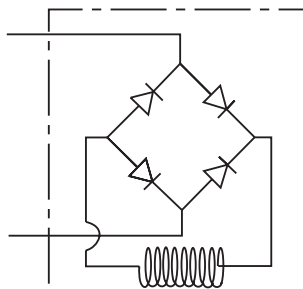

Ordering Information

<b>CA</b>	□	□	□
Super Coil 5/8" I.D.	Wattage	Voltage	Termination

Code	Wattage
<b>S</b>	Standard
<b>P</b>	Puissant

Code	Voltage Volts	Watts		Amps		Ohms**	
		S	P	S	P	S	P
<b>010</b>	10 VDC	18	28	1.80	2.80	5.56	3.57
<b>012*</b>	12 VDC	18	28	1.50	2.33	8.00	5.14
<b>018</b>	18 VDC	18	28	1.00	1.56	18.0	11.6
<b>024*</b>	24 VDC	18	28	0.75	1.17	32.0	20.6
<b>048</b>	48 VDC	18	28	0.38	0.58	128.0	82.3
<b>115*</b>	115 VAC	18	28	0.20	0.26	554	417
<b>230</b>	230 VAC	18	28	0.10	0.15	2100	1430

\*Standard \*\*Resistance ±10% at 68°F

Code	Termination
<b>A</b>	Amp Jr. (DC Only)
<b>AD</b>	Amp Jr. with 3 Amp Diode (DC Only)
<b>C</b>	Double Lead Wire with Conduit Connector (AC Only)
<b>D</b>	DIN 43650 (AC or DC, Supplied without DIN Connector)
<b>H</b>	Integral Deutsch
<b>HE</b>	Integral Deutsch with 3 Amp Diode
<b>HS</b>	Integral Deutsch with Internal Seal
<b>L</b>	Double Lead (DC Only)
<b>LD</b>	Double Lead with Deutsch Connector DT04-2P-EP04 (DC Only) (Use 'H' series if possible)
<b>LE</b>	Double Lead with 3 Amp Diode (DC Only)
<b>PF</b>	Double Lead Wire with Packard Female Weather Pack Connector 1201 5792 (DC Only)
<b>PM</b>	Double Lead Wire with Packard Male Weather Pack Connector 1201 0973 (DC Only)
<b>S</b>	Double Spade (DC Only)
<b>W</b>	Double Screw (DC only)
<b>WE</b>	Double Screw with 3 Amp Diode (DC Only)
<b>Y</b>	Single Screw (Internally Grounded, DC Only)

Note: Additional voltages and other terminals are available. Some coils are UL approved. For details please consult factory.

DIN Female Mating Connector: See page CL2  
 Deutsch Mating Connector: # DT06-25  
 Packard Male Weather Pack Connector: 12010973  
 Packard Female Weather Pack Connector: 12015792

**Terminal Styles and Dimensions**

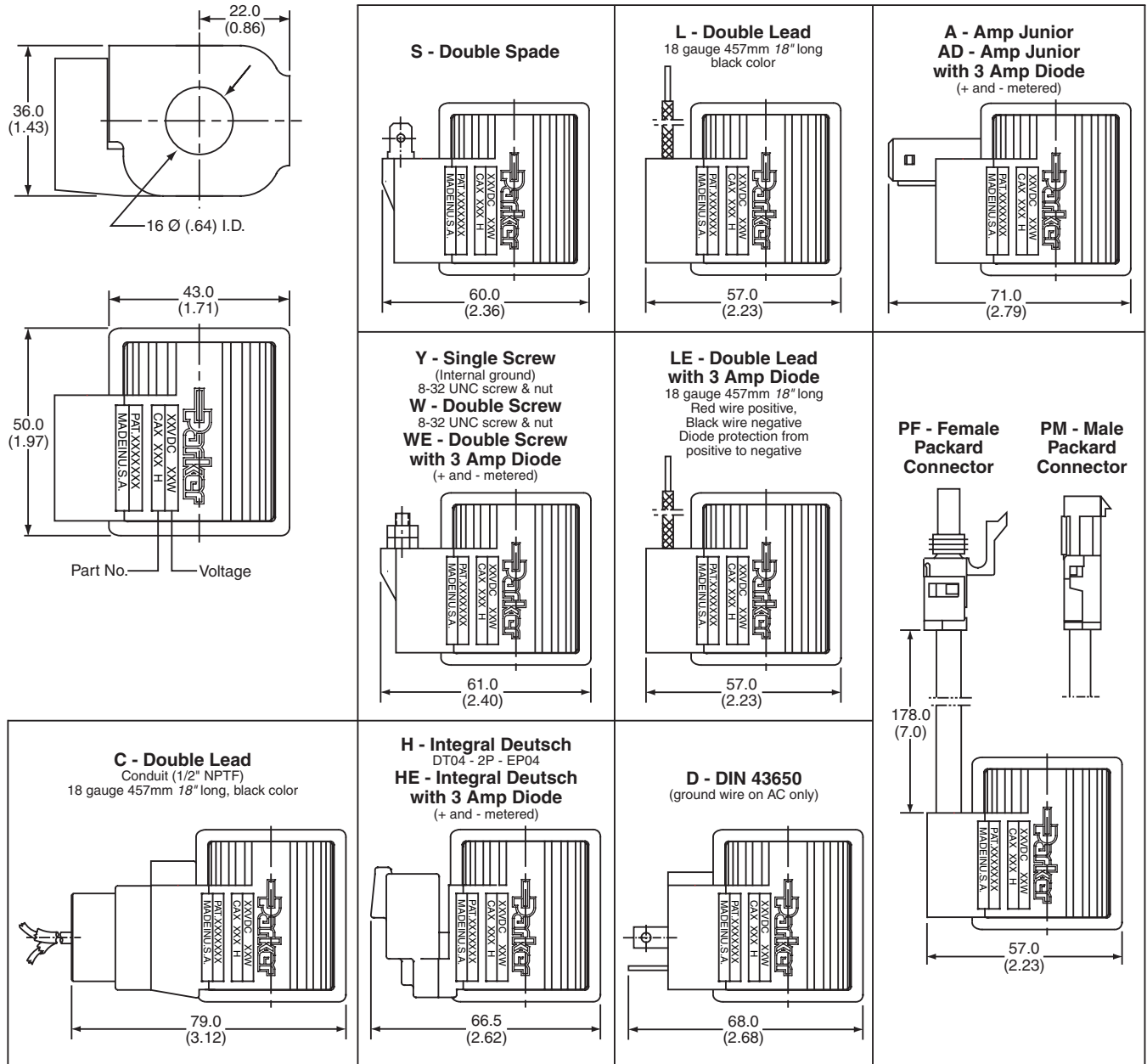

**NOTES:**

1. The standard A.C. coil includes a molded-in full wave rectifier rated for 800 peak reverse voltage.
2. All P Puissant (high wattage) coils use a red ring as an indication marker on the terminal boss. (No ring on Integral Deutsch connector.)

<b>CV</b>
Check Valves
<b>SH</b>
Shuttle Valves
<b>LM</b>
Load/Motor Controls
<b>FC</b>
Flow Controls
<b>PC</b>
Pressure Controls
<b>LE</b>
Logic Elements
<b>DC</b>
Directional Controls
<b>MV</b>
Manual Valves
<b>SV</b>
Solenoid Valves
<b>PV</b>
Proportional Valves
<b>CE</b>
Coils & Electronics
<b>BC</b>
Bodies & Cavities
<b>TD</b>
Technical Data

**Technical Information**

- CV** Check Valves
- SH** Shuttle Valves
- LM** Load/Motor Controls
- FC** Flow Controls
- PC** Pressure Controls
- LE** Logic Elements
- DC** Directional Controls
- MV** Manual Valves
- SV** Solenoid Valves
- PV** Proportional Valves
- CE** Coils & Electronics
- BC** Bodies & Cavities
- TD** Technical Data

**Features**

- Compact one piece encapsulated design
- Minimal amperage draw
- Numerous terminals and voltages
- Coil designed for use with series DSL and DSH type valves only
- Coils made with high quality Class N magnet wire
- Superior thick internal iron frame surrounding copper windings to increase the flux density
- More ampere turns to deliver more magnetic flux per input voltage
- A.C. coil operates @ 50/60 cycle (Hz)

**Specifications**

<b>Wattage</b>	14 Watts
<b>Duty Rating</b>	Continuous @ 100% voltage
<b>Wire Class</b>	Class N - 200°C (392°F)
<b>Heat Rise</b>	45°C (115°F) over ambient
<b>A.C. Rectifier</b>	Integral full wave bridge
<b>Lead Wire</b>	18 gauge 24" long, 600 volt rating
<b>Lead Wire Strain Relief</b>	34 kg (75 lbs.) @ 21°C (70°F) & 18 kg (40 lbs.) @ 93°C (200°F)
<b>Encapsulating Material</b>	Rynite, resistant to moisture, caustic solutions, fungus, and temperatures from -40°C (-40°F) to 200°C (392°F)
<b>Finish</b>	Coil - Black Frame - Yellow zinc dichromate

**Coil Accessories For DIN Connector 43650**

**Cable Gland**

Type	Non-Rectified	Rectified
PG9	710549-00	712126-01
PG11	710549-01	712126-00

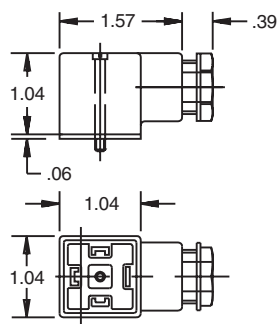

**Conduit**

Rectified
712704-00

**Conduit**

Non-Rectified
710549-02

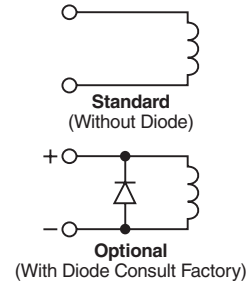
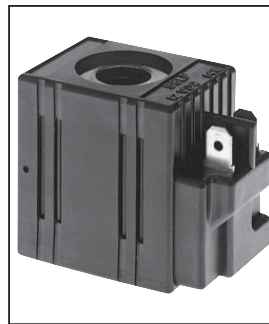
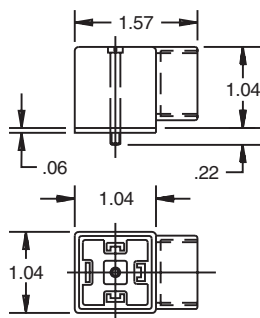
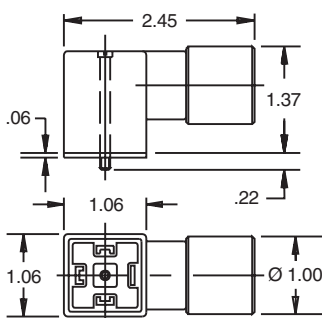

**Ordering Information**

<b>S8</b>	<b>L</b>			
Unicoil 1/2" I.D.	Wattage	Termination	Diode	Voltage

Code	Wattage
L	14 Watt

Code	Diode
Omit	Without Diode
R	Diode

*Diode not available with all connectors.*

Code	Termination
C	*Conduit
D	*DIN Plug Face
J	Amp Jr.
M	Metri-Pack
P	*Dual Spade
S	*Dual Screw
W	Dual Lead
WS	Weather Pack Shroud 24"

*\*Diode not available*

Code	Voltage	Current Amps	Resistance Ohms	Lead Color
*D006	6 VDC	2.40	2.5	Black
*D010	10 VDC	1.45	6.9	Yellow
D012	12 VDC	1.17	10.2	Red
*D018	18 VDC	0.84	21.5	Gray
D024	24 VDC	0.57	41.8	Blue
*D036	36 VDC	0.45	80.5	Orange
*D048	48 VDC	0.32	150.6	Green
A120	120 VAC	0.16	663	Brown
A240	240 VAC	0.07	3032	White

*\* Consult Factory.*



**Terminal Styles and Dimensions**

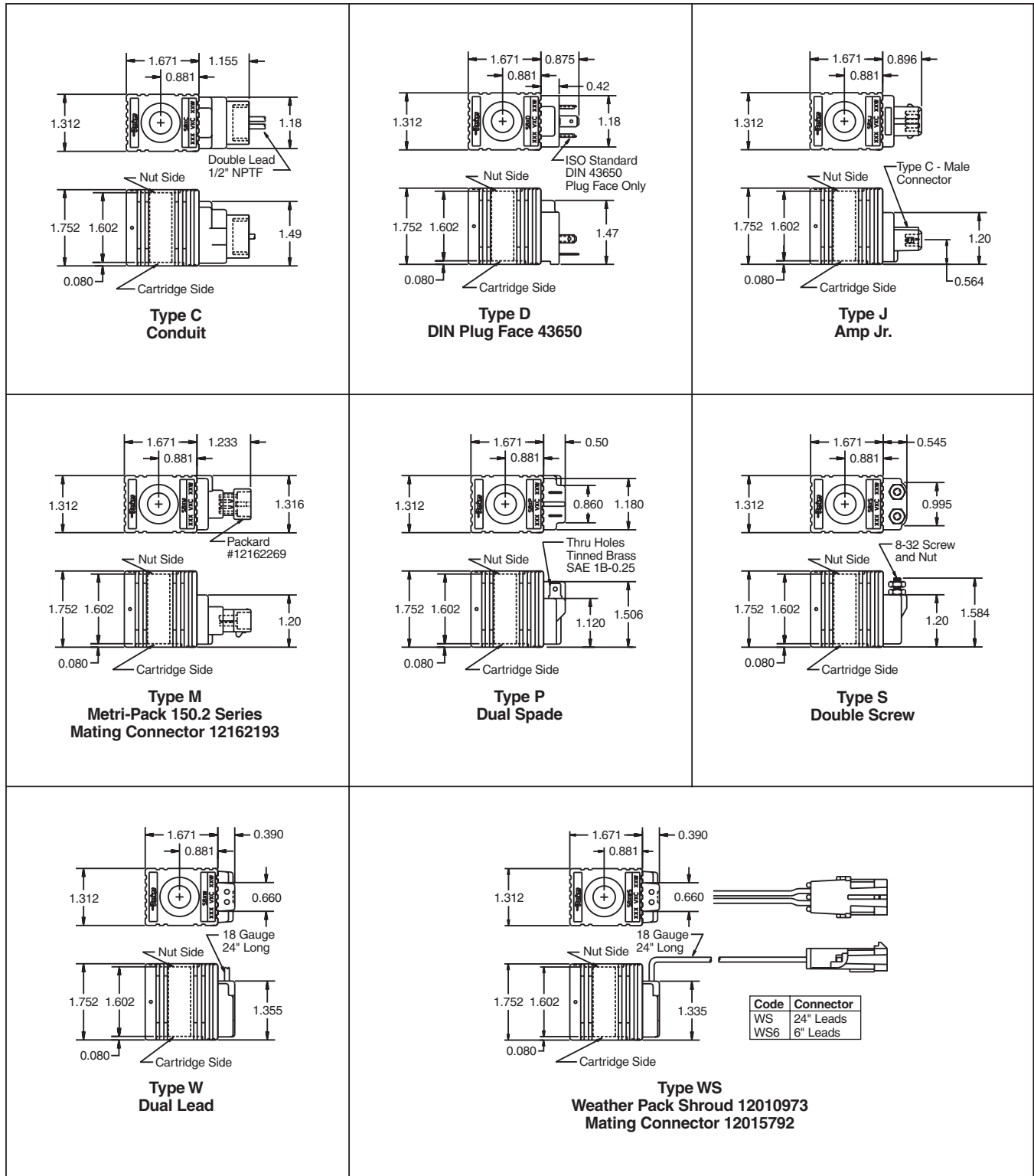

- CV**
- Check Valves
- SH**
- Shuttle Valves
- LM**
- Load/Motor Controls
- FC**
- Flow Controls
- PC**
- Pressure Controls
- LE**
- Logic Elements
- DC**
- Directional Controls
- MV**
- Manual Valves
- SV**
- Solenoid Valves
- PV**
- Proportional Valves
- CE**
- Coils & Electronics
- BC**
- Bodies & Cavities
- TD**
- Technical Data

**Technical Information**

- CV** Check Valves
- SH** Shuttle Valves
- LM** Load/Motor Controls
- FC** Flow Controls
- PC** Pressure Controls
- LE** Logic Elements
- DC** Directional Controls
- MV** Manual Valves
- SV** Solenoid Valves
- PV** Proportional Valves
- CE** Coils & Electronics
- BC** Bodies & Cavities
- TD** Technical Data

**Features**

- Compact one piece encapsulated design
- Minimal amperage draw
- Numerous terminals and voltages
- Coil designed for use with series DSL and DSH type valves only
- Coils made with high quality Class N magnet wire
- Superior thick internal iron frame surrounding copper windings to increase the flux density
- More ampere turns to deliver more magnetic flux per input voltage
- A.C. coil operates @ 50/60 cycle (Hz)

**Specifications**

<b>Wattage</b>	20 Watts
<b>Duty Rating</b>	Continuous @ 100% voltage
<b>Wire Class</b>	Class N - 200°C (392°F)
<b>Heat Rise</b>	45°C (115°F) over ambient
<b>A.C. Rectifier</b>	Integral full wave bridge
<b>Lead Wire</b>	18 gauge 24" long, 600 volt rating
<b>Lead Wire Strain Relief</b>	34 kg (75 lbs.) @ 21°C (70°F) & 18 kg (40 lbs.) @ 93°C (200°F)
<b>Encapsulating Material</b>	Rynite, resistant to moisture, caustic solutions, fungus, and temperatures from -40°C (-40°F) to 200°C (392°F)
<b>Finish</b>	Coil - Black Frame - Yellow zinc dichromate

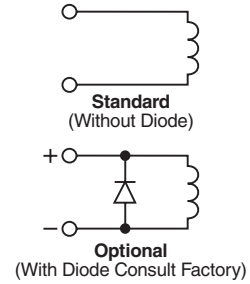
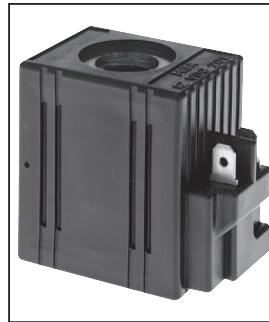

**Ordering Information**

<b>S10</b>	<b>L</b>			
Unicoil 5/8" I.D.	Wattage	Termination	Diode	Voltage

Code	Wattage
L	20 Watt

Code	Diode
Omit	Without Diode
R	Diode

*Diode not available with all connectors.*

Code	Termination
C	*Conduit
D	*DIN Plug Face
J	Amp Jr.
M	Metri-Pack
P	*Dual Spade
S	*Dual Screw
W	Dual Lead
WS	Weather Pack Shroud 24"

*\*Diode not available*

Code	Voltage	Current Amps	Resistance Ohms	Lead Color
*D006	6 VDC	3.33	1.8	Black
*D010	10 VDC	2.10	4.8	Yellow
D012	12 VDC	1.67	7.2	Red
*D018	18 VDC	1.21	14.9	Gray
D024	24 VDC	0.88	27.4	Blue
*D036	36 VDC	0.61	58.9	Orange
*D048	48 VDC	0.47	102.4	Green
A120	120 VAC	0.192	626	Brown
A240	240 VAC	0.10	2400	White

*\* Consult Factory.*

**Coil Accessories For DIN Connector 43650**

**Cable Gland**

Type	Non-Rectified	Rectified
PG9	710549-00	712126-01
PG11	710549-01	712126-00

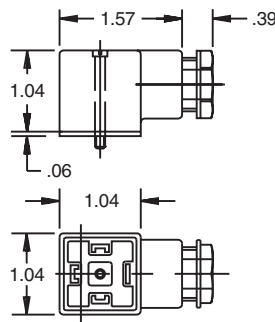

**Conduit**

Rectified
712704-00

**Conduit**

Non-Rectified
710549-02

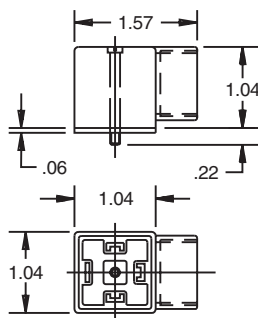
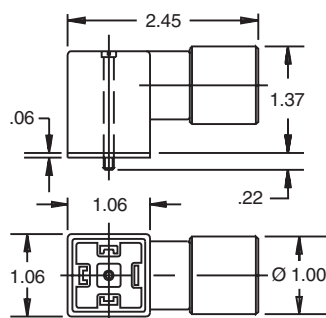

**Terminal Styles and Dimensions**

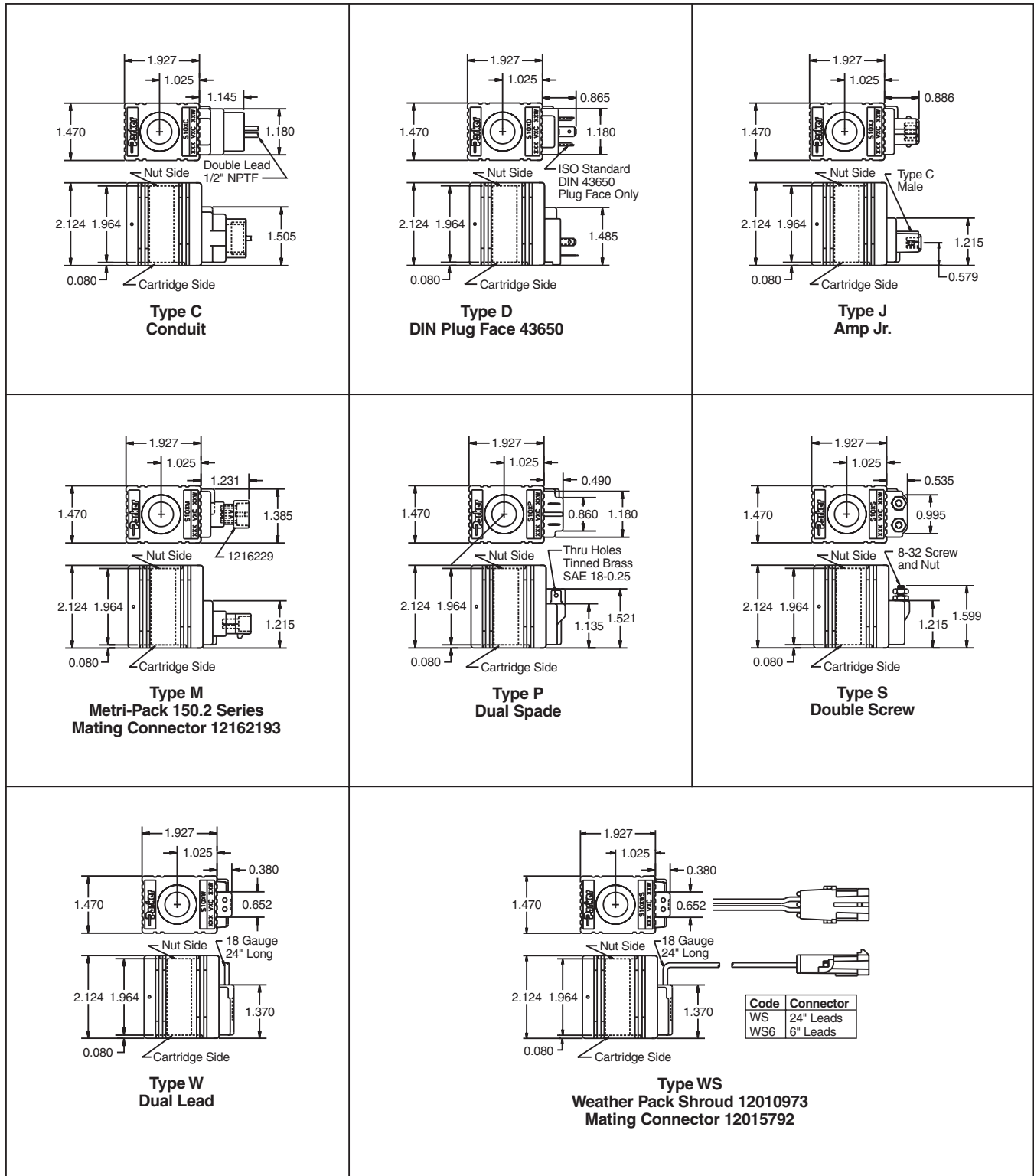

**CV**  
Check Valves

**SH**  
Shuttle Valves

**LM**  
Load/Motor Controls

**FC**  
Flow Controls

**PC**  
Pressure Controls

**LE**  
Logic Elements

**DC**  
Directional Controls

**MV**  
Manual Valves

**SV**  
Solenoid Valves

**PV**  
Proportional Valves

**CE**  
Coils & Electronics

**BC**  
Bodies & Cavities

**TD**  
Technical Data

Technical Information

CV Check Valves  
SH Shuttle Valves  
LM Load/Motor Controls  
FC Flow Controls  
PC Pressure Controls  
LE Logic Elements  
DC Directional Controls  
MV Manual Valves  
SV Solenoid Valves  
PV Proportional Valves  
CE Coils & Electronics  
BC Bodies & Cavities  
TD Technical Data

Features

- Compact one piece encapsulated design
- Minimal amperage draw
- Numerous terminals and voltages
- High watt design available for intermittent operation
- Heavy gauge color coded lead wire with built-in strain relief
- 180°C Class H wire standard
- 200°C Class N wire on high watt models

Specifications

<b>Wattage</b>	12 Watts — Standard - Black Coil 25 Watts — High Watt - Red Coil
<b>Duty Rating</b>	Continuous @ 100% voltage
<b>Wire Class</b>	Class H for all voltages 12 Watt Class N for all voltages 25 Watt
<b>A.C. Rectifier</b>	Integral full wave bridge
<b>Lead Wire</b>	18 gauge 24" long, 600 volt rating
<b>Lead Wire Strain Relief</b>	34 kg (75 lbs.) @ 21°C (70°F) & 18 kg (40 lbs.) @ 93°C (200°F)
<b>Encapsulating Material</b>	Glass filled nylon, resistant to moisture, caustic solutions, fungus, and temperatures from -40°C (-40°F) to 200°C (392°F)

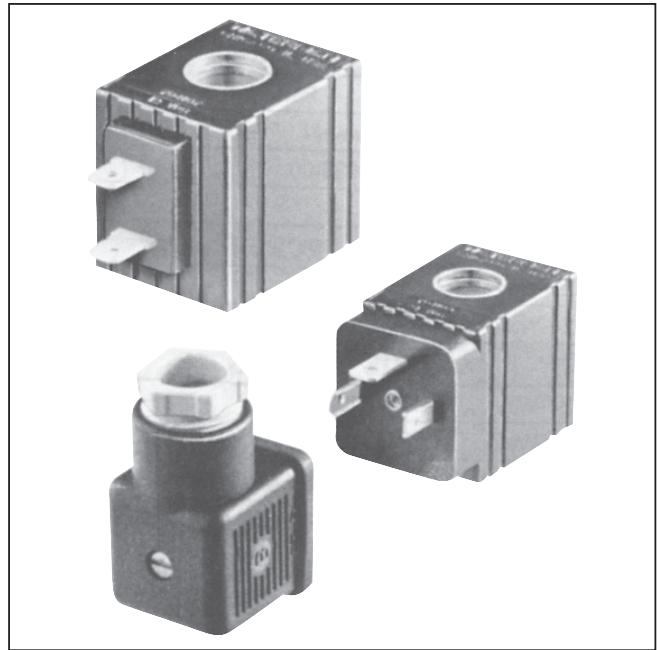

Symbol

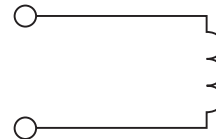

AC Coil Assembly

No inductive or capacitive loads can be installed between surge suppressor and rectified valves.

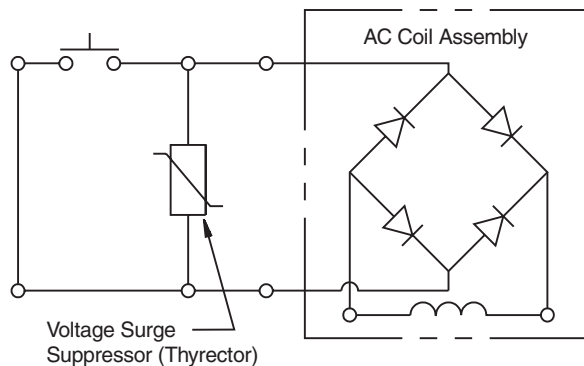

NOTE:

Parker A.C. Coils incorporate integrally molded full wave rectifiers which are rated for reverse voltage peaks of 1000 volts maximum. For voltage transients greater than 1000 volts P.I.V., Harris Thyrector V150LA10A or V150LA20A for 115 VAC and V250LA15A or V250LA40A for 200 VAC is recommended.

**Terminal Styles and Dimensions**

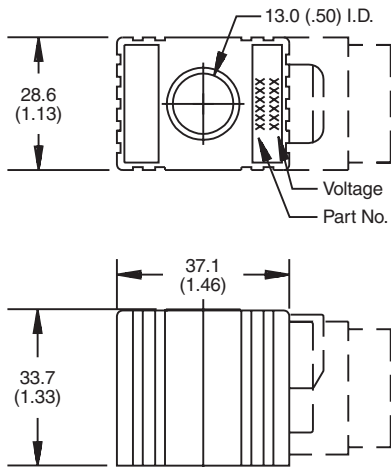

<p><b>Type P Dual Spade</b></p> <p>Thru Hole Tinned Brass SAE 1B-0.25</p> <p>33.5 (1.32)</p>	<p><b>Type W Dual Lead</b></p> <p>18 Gauge 24" Long</p> <p>25.8 (1.02)</p>	<p><b>Type C Double Lead With Conduit Connector</b> (1/2" NPTF)</p> <p>18 Gauge 24" Long</p> <p>40.4 (1.59)</p>
<p><b>Type D DIN</b></p> <p>DIN 43650 Plug Face Only</p> <p>36.6 (1.44)</p>	<p><b>Type S Double Screw</b></p> <p>8-32 Screw &amp; Nut</p> <p>33.1 (1.31)</p>	<p><b>Type J AMP Junior Timer Type C</b></p> <p>40.8 (1.61)</p>

**NOTES:**

1. Coil to be installed with part number on nut side.
2. For additional terminals, voltages and wattages, consult factory for details.

**Coil Part Numbers**

Voltage	Watts	Type P Double Spade	Type W Double Lead	Type C Conduit Connector	Type D DIN Plug Face	Type S Double Screw	Amps†	Lead Wire Color
**6 VDC	12	851007-006	851009-006	851003-006*	851005-006*	851011-006	2.22	Black
	25	851008-006	851010-006	851004-006	851006-006	851012-006	3.90	
**10 VDC	12	851007-010	851009-010	851003-010*	851005-010*	851011-010	1.43	Yellow
	25	851008-010	851010-010	851004-010	851006-010	851012-010	2.48	
12 VDC	12	851007-012	851009-012	851003-012*	851005-012*	851011-012	1.05	Red
	25	851008-012	851010-012	851004-012	851006-012	851012-012	1.94	
**18 VDC	12	851007-018	851009-018	851003-018*	851005-018*	851011-018	0.75	Gray
	25	851008-018	851010-018	851004-018	851006-018	851012-018	1.42	
24 VDC	12	851007-024	851009-024	851003-024*	851005-024*	851011-024	0.52	Blue
	25	851008-024	851010-024	851004-024	851006-024	851012-024	1.17	
**36 VDC	12	851007-036	851009-036	851003-036*	851005-036*	851011-036	0.38	Orange
	25	851008-036	851010-036	851004-036	851006-036	851012-036	0.73	
**48 VDC	12	851007-048	851009-048	851003-048*	851005-048*	851011-048	0.26	Green
	25	851008-048	851010-048	851004-048	851006-048	851012-048	0.59	
120 VAC	12			851003-120	851005-120		0.14	Brown
	25			851004-120	851006-120		0.23	
230 VAC	12			851003-240	851005-240		0.08	White
	25			851004-240	851006-240		0.12	
**440 VAC	12			851003-480	851005-480		0.04	Violet
	25			851004-480	851006-480		0.07	

\*\*Consult Factory \*UL Listed

†Amperage draw @ 21°C (70°F)

- CV**
- Check Valves
- SH**
- Shuttle Valves
- LM**
- Load/Motor Controls
- FC**
- Flow Controls
- PC**
- Pressure Controls
- LE**
- Logic Elements
- DC**
- Directional Controls
- MV**
- Manual Valves
- SV**
- Solenoid Valves
- PV**
- Proportional Valves
- CE**
- Coils & Electronics
- BC**
- Bodies & Cavities
- TD**
- Technical Data

**Technical Information**

**CV**

Check Valves

**SH**

Shuttle Valves

**LM**

Load/Motor Controls

**FC**

Flow Controls

**PC**

Pressure Controls

**LE**

Logic Elements

**DC**

Directional Controls

**MV**

Manual Valves

**SV**

Solenoid Valves

**PV**

Proportional Valves

**CE**

Coils & Electronics

**BC**

Bodies & Cavities

**TD**

Technical Data

**Features**

- Compact one piece encapsulated design
- Minimal amperage draw
- Numerous terminals and voltages
- High watt design optional
- Heavy gauge color coded lead wire with built-in strain relief
- 180°C Class H wire standard
- 200°C Class N wire on high watt models

**Specifications**

<b>Wattage</b>	17 Watts — Standard - Black Coil 30 Watts — High Watt - Red Coil
<b>Duty Rating</b>	Continuous @ 100% voltage
<b>Wire Class</b>	Class H for all voltages 17 Watt Class N for all voltages 30 Watt
<b>A.C. Rectifier</b>	Integral full wave bridge
<b>Lead Wire</b>	18 gauge 24" long, 600 volt rating
<b>Lead Wire Strain Relief</b>	34 kg (75 lbs.) @ 21°C (70°F) & 18 kg (40 lbs.) @ 93°C (200°F)
<b>Encapsulating Material</b>	Glass filled nylon, resistant to moisture, caustic solutions, fungus, and temperatures from -40°C (-40°F) to 200°C (392°F)

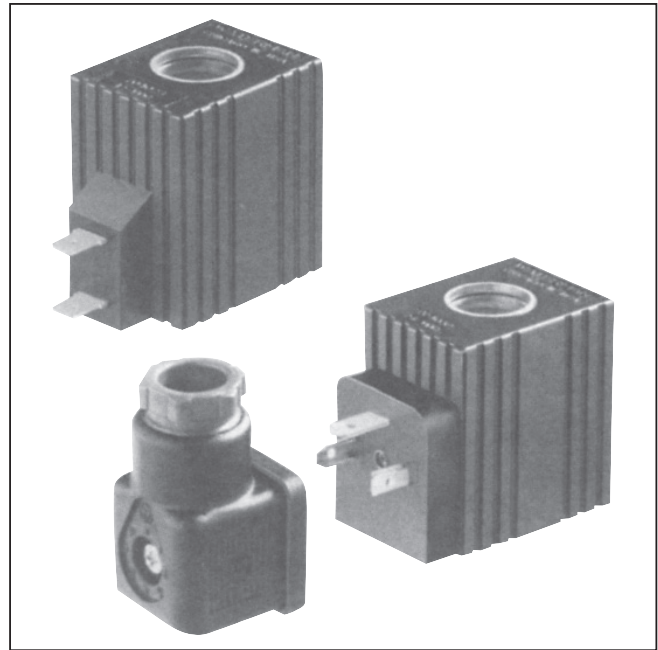

**Symbol**

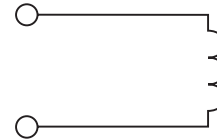

**AC Coil Assembly**

No inductive or capacitive loads can be installed between surge suppressor and rectified valves.

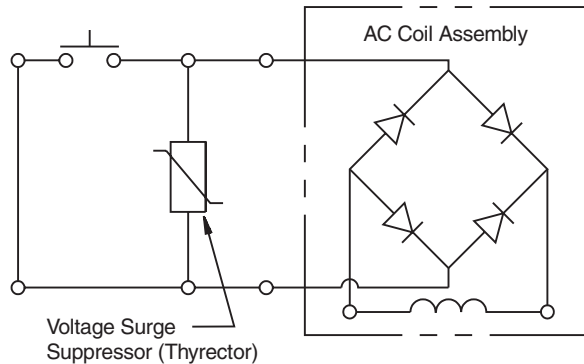

**NOTE:**

Parker A.C. Coils incorporate integrally molded full wave rectifiers which are rated for reverse voltage peaks of 1000 volts maximum. For voltage transients greater than 1000 volts P.I.V., Harris Thyrector V150LA10A or V150LA20A for 115 VAC and V250LA15A or V250LA40A for 200 VAC is recommended.

**Terminal Styles and Dimensions**

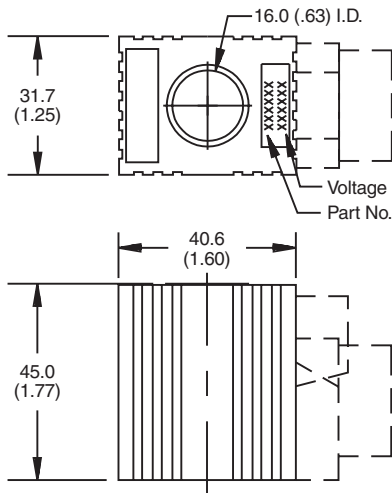

<p><b>Type P Dual Spade</b> Thru Hole Tinned Brass SAE 1B-0.25</p>	<p><b>Type W Dual Lead</b> 18 Gauge 24" Long</p>	<p><b>Type C Double Lead With Conduit Connector</b> (1/2" NPTF) 18 Gauge 24" Long</p>
<p><b>Type D DIN</b> DIN 43650 Plug Face Only</p>	<p><b>Type J AMP Junior Timer Type C</b></p>	

**NOTES:**

1. Coil to be installed with part number on nut side.
2. For additional terminals, voltages and wattages, consult factory for details.

**Coil Part Numbers**

Voltage	Watts	Type P Double Spade	Type W Double Lead	Type C Conduit Connector	Type D DIN Plug Face	Amps*	Lead Wire Color
6 VDC	17	851021-006	851023-006	851017-006	851019-006	2.43	Black
	30	851022-006	851024-006	851018-006	851020-006	4.84	
10 VDC	17	851021-010	851023-010	851017-010	851019-010	1.58	Yellow
	30	851022-010	851024-010	851018-010	851020-010	3.28	
12 VDC	17	851021-012	851023-012	851017-012	851019-012	1.44	Red
	30	851022-012	851024-012	851018-012	851020-012	2.30	
18 VDC	17	851021-018	851023-018	851017-018	851019-018	0.94	Gray
	30	851022-018	851024-018	851018-018	851020-018	1.86	
24 VDC	17	851021-024	851023-024	851017-024	851019-024	0.72	Blue
	30	851022-024	851024-024	851018-024	851020-024	1.20	
36 VDC	17	851021-036	851023-036	851017-036	851019-036	0.43	Orange
	30	851022-036	851024-036	851018-036	851020-036	0.88	
48 VDC	17	851021-048	851023-048	851017-048	851019-048	0.30	Green
	30	851022-048	851024-048	851018-048	851020-048	0.58	
120 VAC	17			851017-120	851019-120	0.15	Brown
	30			851018-120	851020-120	0.24	
230 VAC	17			851017-240	851019-240	0.08	White
	30			851018-240	851020-240	0.13	
440 VAC	17			851017-480	851019-480	0.04	Violet
	30			851018-480	851020-480	0.07	

\*Amperage draw @ 21°C (70°F)

- CV**
- Check Valves
- SH**
- Shuttle Valves
- LM**
- Load/Motor Controls
- FC**
- Flow Controls
- PC**
- Pressure Controls
- LE**
- Logic Elements
- DC**
- Directional Controls
- MV**
- Manual Valves
- SV**
- Solenoid Valves
- PV**
- Proportional Valves
- CE**
- Coils & Electronics
- BC**
- Bodies & Cavities
- TD**
- Technical Data

Technical Information

- CV Check Valves
- SH Shuttle Valves
- LM Load/Motor Controls
- FC Flow Controls
- PC Pressure Controls
- LE Logic Elements
- DC Directional Controls
- MV Manual Valves
- SV Solenoid Valves
- PV Proportional Valves
- CE Coils & Electronics
- BC Bodies & Cavities
- TD Technical Data

Features

- Compact one piece encapsulated design
- Numerous terminals and voltages
- Heavy gauge color coded lead wire with built-in strain relief
- 200°C Class N wire standard
- U.L. recognized on most DC coils (consult factory)

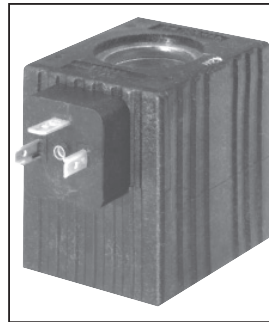

Specifications

<b>Wattage</b>	42 Watts — Standard 30 Watts — Low Watt
<b>Duty Rating</b>	Continuous @ 100% voltage
<b>Wire Class</b>	Class N for all voltages
<b>Lead Wire</b>	18 gauge 24" long, 600 volt rating
<b>Lead Wire Strain Relief</b>	34 kg (75 lbs.) @ 21°C (70°F) & 18 kg (40 lbs.) @ 93°C (200°F)
<b>Encapsulating Material</b>	Glass filled nylon, resistant to moisture, caustic solutions, fungus, and temperatures from -40°C (-40°F) to 200°C (392°F)
<b>Color</b>	Black

AC Coil Assembly

No inductive or capacitive loads can be installed between surge suppressor and rectified valves.

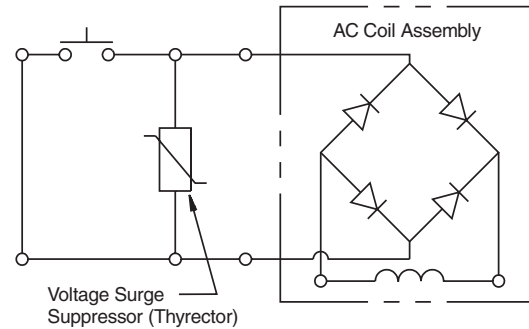

Terminal Styles and Dimensions

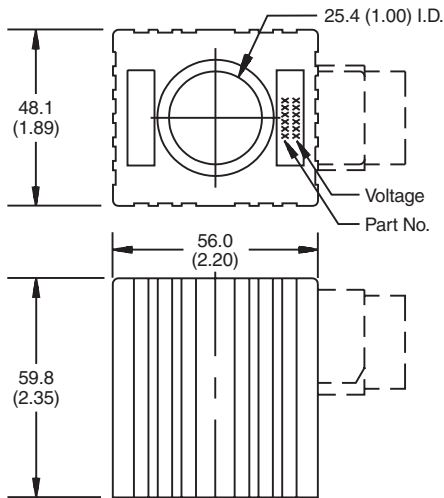

NOTES:

1. Coil to be installed with part number on nut side.
2. For additional terminals, voltages and wattages, consult factory for details.

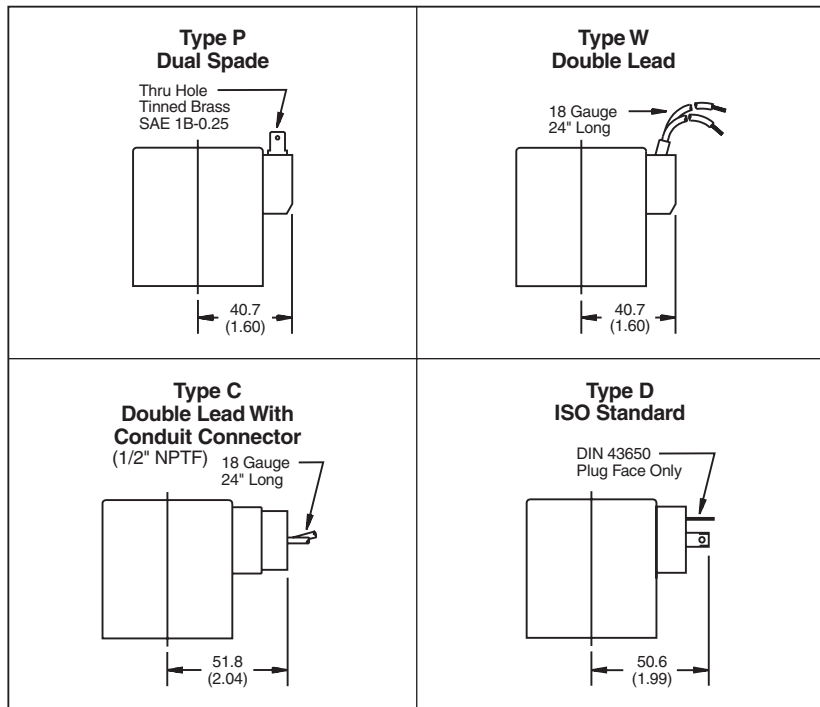

Coil Part Numbers

Wattage	Voltage	Type P Double Spade	Type W Double Lead	Type D ISO STANDARD	Amps	Lead Wire Color
42 Watts	12 VDC	851060-012*	851062-012*	851058-012*	3.53	Red
42 Watts	24 VDC	851060-024*	851062-024*	851058-024*	1.79	Blue
30 Watts	12 VDC	853496-012	853497-012	853495-012	2.50	Red
30 Watts	24 VDC	853496-024	853497-024	853495-024	1.25	Blue

\*UL Listed







**Technical Information**

- CV** Check Valves
- SH** Shuttle Valves
- LM** Load/Motor Controls
- FC** Flow Controls
- PC** Pressure Controls
- LE** Logic Elements
- DC** Directional Controls
- MV** Manual Valves
- SV** Solenoid Valves
- PV** Proportional Valves
- CE** Coils & Electronics
- BC** Bodies & Cavities
- TD** Technical Data

**General Description**

Proportional Valve Controllers. 12 and 24 Volts, PWM. For additional information see Technical Tips on pages CE1-CE2.

**Operation**

The 902/932 and 904/934 are valve top mounted PWM controllers for proportional control valves. They can be used with an external potentiometer to give accurate current control using the units internal reference voltage. Alternatively these controllers can be used with a 0-10V command signal from a PLC or engine management system.

'I Max' adjustment is provided to allow the maximum output current to be set via a 12 turn potentiometer. Turn clockwise to increase the output current.

**Notes:**

**XPRO902 and XPRO932**

In order to avoid damaging a controller the +8V (yellow) lead must not be shorted to the +12V (red) lead or to the 0V (blue) lead.

**XPRO904 and XPRO934**

In order to avoid damaging a controller the +15V (yellow) lead must not be shorted to the +24V (red) lead or to the 0V (blue) lead.

**Specifications**

<b>Nominal Voltage</b>	XPRO902 12V DC XPRO932 12V DC XPRO904 24V DC XPRO934 24V DC
<b>Maximum Power</b>	XPRO902 19W XPRO932 30W XPRO904 19W XPRO934 30W
<b>(IP) Rating</b>	IP 65
<b>Maximum Current</b>	XPRO902 1.6A XPRO932 2.6A XPRO904 1.0A XPRO934 1.4A
<b>Command Voltage</b>	0 - 10V
<b>Input Resistance</b>	10K ohms
<b>Reference Voltage</b>	XPRO902 +8V (2mA) XPRO932 +8V (2mA) XPRO904 +15V (2mA) XPRO934 +15V (2mA)
<b>Cable Length</b>	1 meter
<b>Frequency</b>	110 Hz ±5%

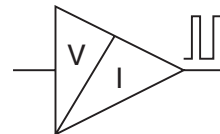
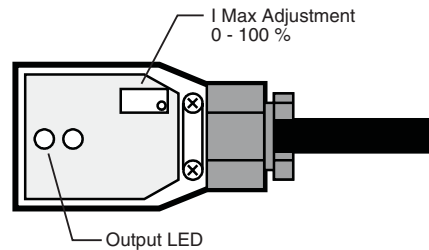

**Features**

- Self contained DIN 'Plug Top'
- High impact resistant molded ABS
- Complies with current CE regulations

**Output Regulation**

(Curve shows coil temperature compensation)

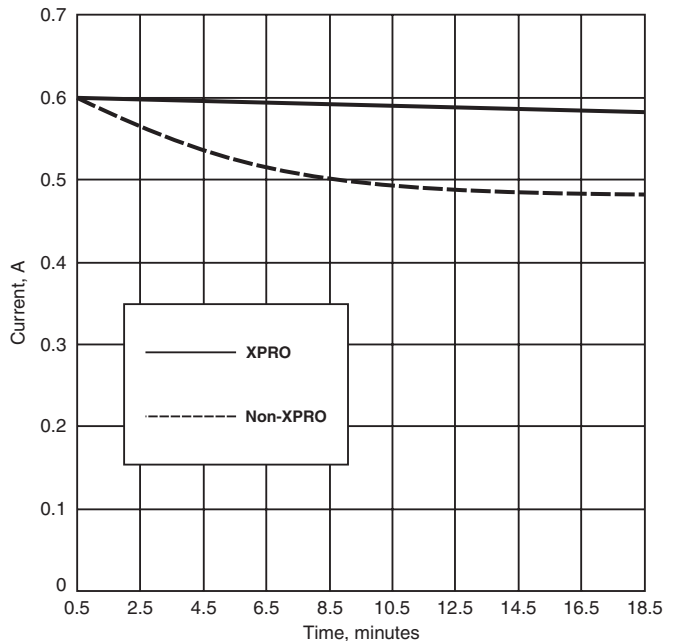

**Application**

For use with most proportional valves. GP, HP, JP, GTP and AP series valves.

**Dimensions** Millimeters (Inches)

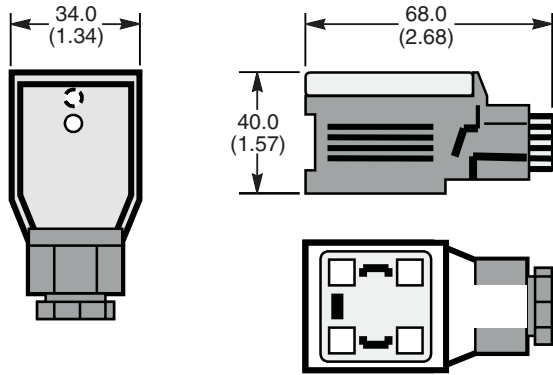

**Ordering Information**



Code	Maximum Current
902	1.6A
932	2.6A
904	1.0A
934	1.4A

**Connection Details**

**XPRO902 and XPRO932**

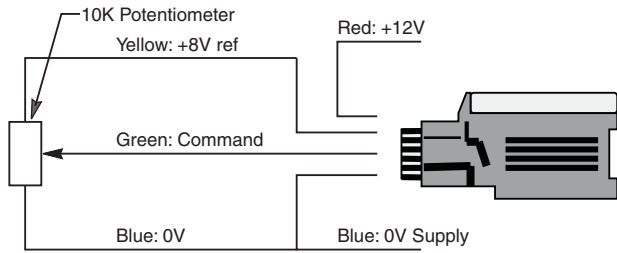

**XPRO904 and XPRO934**

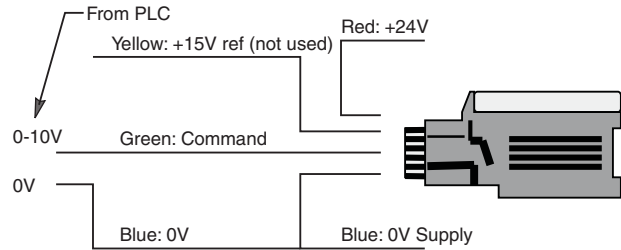
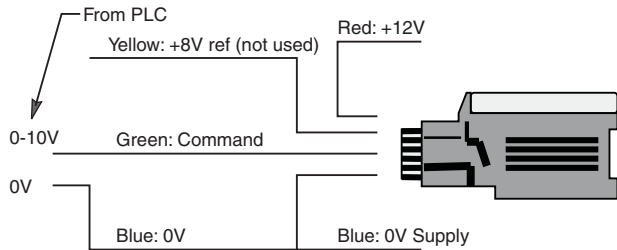
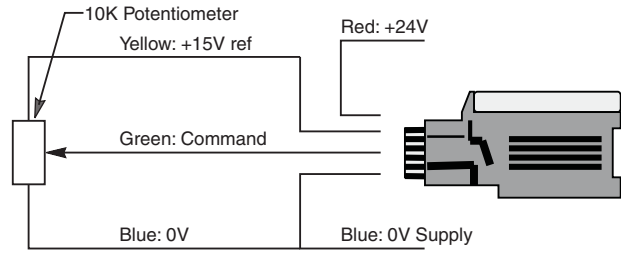

**Controller / Coil Combination**

Coil	Controller	
	XPRO 902	XPRO 932
CCS012D	X	
CCP012D	X	
CAS012D	X	
CAP012D		X

Coil	Controller	
	XPRO 904	XPRO 934
CCS024D	X	
CCP024D	X	
CAS024D	X	
CAP024D		X

- CV** Check Valves
- SH** Shuttle Valves
- LM** Load/Motor Controls
- FC** Flow Controls
- PC** Pressure Controls
- LE** Logic Elements
- DC** Directional Controls
- MV** Manual Valves
- SV** Solenoid Valves
- PV** Proportional Valves
- CE** Coils & Electronics
- BC** Bodies & Cavities
- TD** Technical Data

**Technical Information**

- CV** Check Valves
- SH** Shuttle Valves
- LM** Load/Motor Controls
- FC** Flow Controls
- PC** Pressure Controls
- LE** Logic Elements
- DC** Directional Controls
- MV** Manual Valves
- SV** Solenoid Valves
- PV** Proportional Valves
- CE** Coils & Electronics
- BC** Bodies & Cavities
- TD** Technical Data

**General Description**

Proportional Valve Controllers. 12 and 24 Volts, PWM with Adjustable Dither. For additional information see Technical Tips on pages CE1-CE2.

**Operation**

The 902d/932d and 904d/934d are valve top mounted PWM controllers for proportional control valves. They can be used with an external potentiometer to give accurate current control using the units internal reference voltage. Alternatively these controllers can be used with a 0-10V command signal from a PLC or engine management system.

'I Max' adjustment is provided to allow the maximum output current to be set via a 12 turn potentiometer. Turn clockwise to increase the output current.

Dither adjustment POT is used to alter the PWM frequency of the controller from 95 HZ to 230 Hz. By changing the frequency this pot controls the amount of dither imposed on the valve. Lower frequency = more dither, higher frequency = less dither. Turn clockwise to increase frequency.

**Notes:**

**XPRO902d and XPRO932d**

In order to avoid damaging a controller the +8V (yellow) lead must not be shorted to the +12V (red) lead or to the 0V (blue) lead.

**XPRO904d and XPRO934d**

In order to avoid damaging a controller the +15V (yellow) lead must not be shorted to the +24V (red) lead or to the 0V (blue) lead.

**Specifications**

<b>Nominal Voltage</b>	XPRO902d	12V DC
	XPRO932d	12V DC
	XPRO904d	24V DC
	XPRO934d	24V DC
<b>Maximum Power</b>	XPRO902d	19W
	XPRO932d	30W
	XPRO904d	19W
	XPRO934d	30W
<b>(IP) Rating</b>	IP 65	
<b>Maximum Current</b>	XPRO902d	1.6A
	XPRO932d	2.6A
	XPRO904d	1.0A
	XPRO934d	1.4A
<b>Command Voltage</b>	0 - 10V	
<b>Input Resistance</b>	10K ohms	
<b>Reference Voltage</b>	XPRO902d	+8V (2mA)
	XPRO932d	+8V (2mA)
	XPRO904d	+15V (2mA)
	XPRO934d	+15V (2mA)
<b>Cable Length</b>	1 meter	
<b>Frequency</b>	95 Hz - 230 Hz	

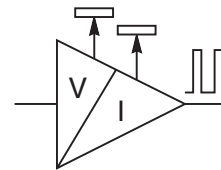
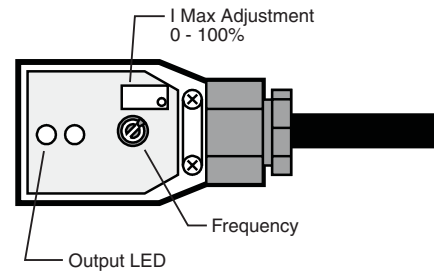

**Features**

- Self contained DIN 'Plug Top'
- High impact resistant molded ABS
- Complies with current CE regulations

**Output Regulation**

(Curve shows coil temperature compensation)

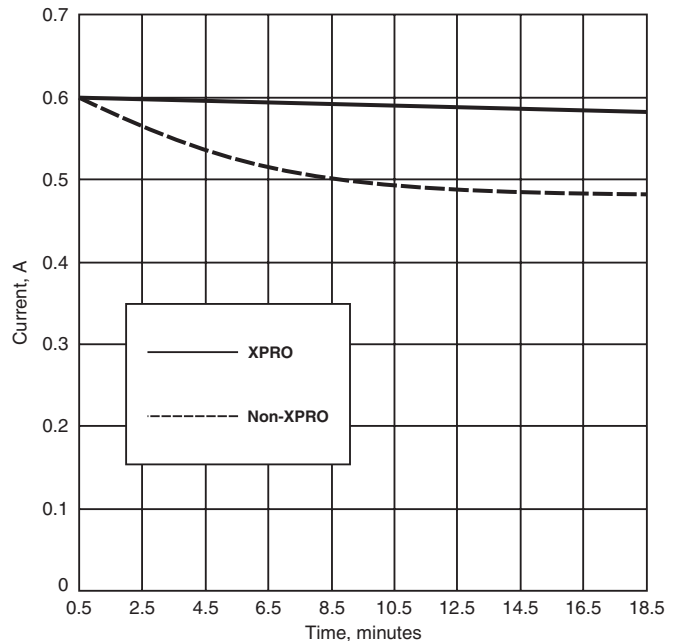

**Application**

For use with most proportional valves. GP, HP, JP, GTP and AP series valves.

**Dimensions** Millimeters (Inches)

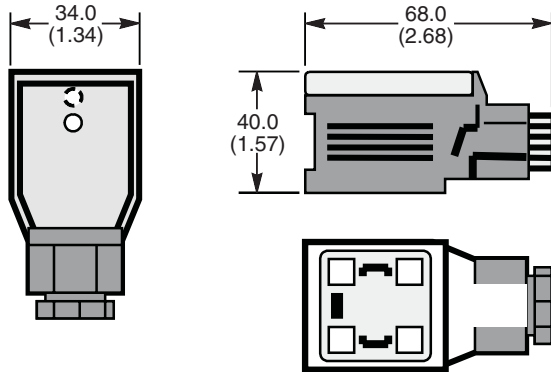

**Ordering Information**



Code	Maximum Current
902d	1.6A
932d	2.6A
904d	1.0A
934d	1.4A

Setting for standard:  
 Dither frequency: 110 HZ

**Connection Details**

**XPRO902d and XPRO932d**

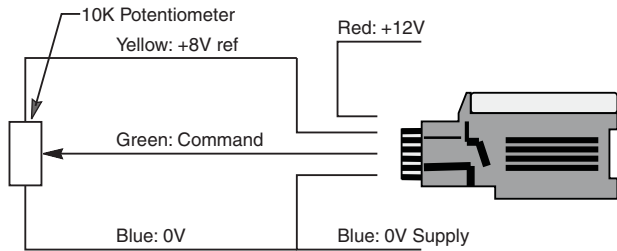

**XPRO904d and XPRO934d**

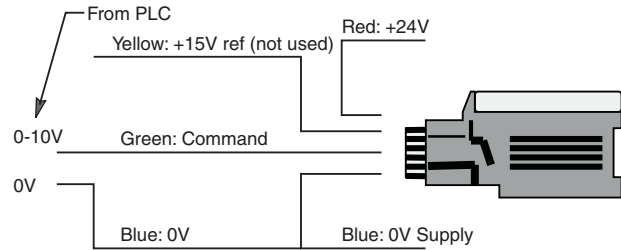
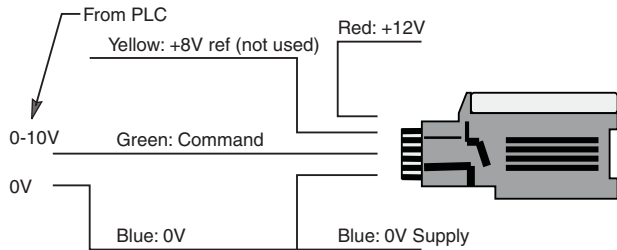
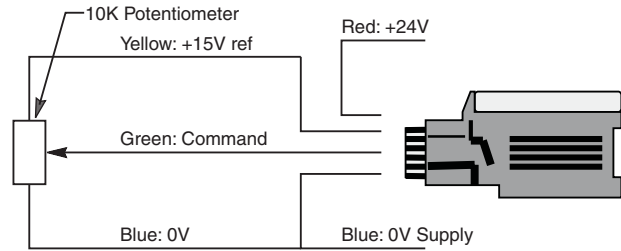

**Controller / Coil Combination**

Coil	Controller	
	XPRO 902d	XPRO 932d
CCS012D	X	
CCP012D	X	
CAS012D	X	
CAP012D		X

Coil	Controller	
	XPRO 904d	XPRO 934d
CCS024D	X	
CCP024D	X	
CAS024D	X	
CAP024D		X

- CV** Check Valves
- SH** Shuttle Valves
- LM** Load/Motor Controls
- FC** Flow Controls
- PC** Pressure Controls
- LE** Logic Elements
- DC** Directional Controls
- MV** Manual Valves
- SV** Solenoid Valves
- PV** Proportional Valves
- CE** Coils & Electronics
- BC** Bodies & Cavities
- TD** Technical Data

**Technical Information**

- CV** Check Valves
- SH** Shuttle Valves
- LM** Load/Motor Controls
- FC** Flow Controls
- PC** Pressure Controls
- LE** Logic Elements
- DC** Directional Controls
- MV** Manual Valves
- SV** Solenoid Valves
- PV** Proportional Valves
- CE** Coils & Electronics
- BC** Bodies & Cavities
- TD** Technical Data

**General Description**

Proportional Valve Controllers. 12 and 24 Volts, PWM with Multiple Adjustments. For additional information see Technical Tips on pages CE1-CE2.

**Operation**

The 902rid/932rid and 904rid/934rid are valve top mounted PWM controllers for proportional control valves. They can be used with an external potentiometer to give accurate current control using the units internal reference voltage. Alternatively these controllers can be used with a 0-10V command signal from a PLC or engine management system.

'I' Max adjustment is provided to allow the maximum output current to be set via a 12 turn potentiometer. Turn clockwise to increase the output current.

Ramp Up and Ramp Down adjustments provide independent, linear control of the time it takes, to reach 'I' Max and to switch off, up to 8 seconds of delay. Turn clockwise for slower ramps.

'I' Min adjustment Pot sets the minimum current the controller will jump to when a command signal is present, used to eliminate dead band in a slow ramp. Turn clockwise for a higher 'I' Min setting.

Dither adjustment Pot is used to alter the PWM frequency of the controller from 95 HZ to 230 HZ. By changing the frequency this pot controls the amount of dither imposed on the valve. Lower frequency = more dither, higher frequency = less dither. Turn clockwise to increase frequency.

**Notes:**

**XPRO902rid and XPRO932rid**

In order to avoid damaging a controller the +8V (yellow) lead must not be shorted to the +12V (red) lead or to the 0V (blue) lead.

**XPRO904rid and XPRO934rid**

In order to avoid damaging a controller the +15V (yellow) lead must not be shorted to the +24V (red) lead or to the 0V (blue) lead.

**Specifications**

<b>Nominal Voltage</b>	XPRO902rid & 932rid 12V DC XPRO904rid & 934rid 24V DC
<b>Maximum Power</b>	XPRO902rid & 904rid 19W XPRO932rid & 934rid 30W
<b>(IP) Rating</b>	IP 65
<b>Maximum Current</b>	XPRO902rid 1.6A XPRO932rid 2.6A XPRO904rid 1.0A XPRO934rid 1.4A
<b>Command Voltage</b>	0 - 10V
<b>Input Resistance</b>	10K ohms
<b>Reference Voltage</b>	XPRO902rid & 932rid +8V (2mA) XPRO904rid & 934rid +15V (2mA)
<b>Cable Length</b>	1 meter
<b>Ramp Up/Down</b>	200ms - 8s

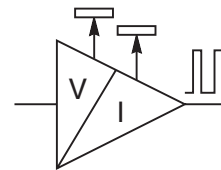
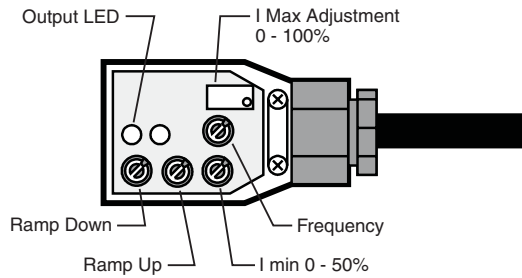

**Features**

- Self contained DIN 'Plug Top'
- High impact resistant molded ABS
- Complies with current CE regulations

**Output Regulation**

(Curve shows coil temperature compensation)

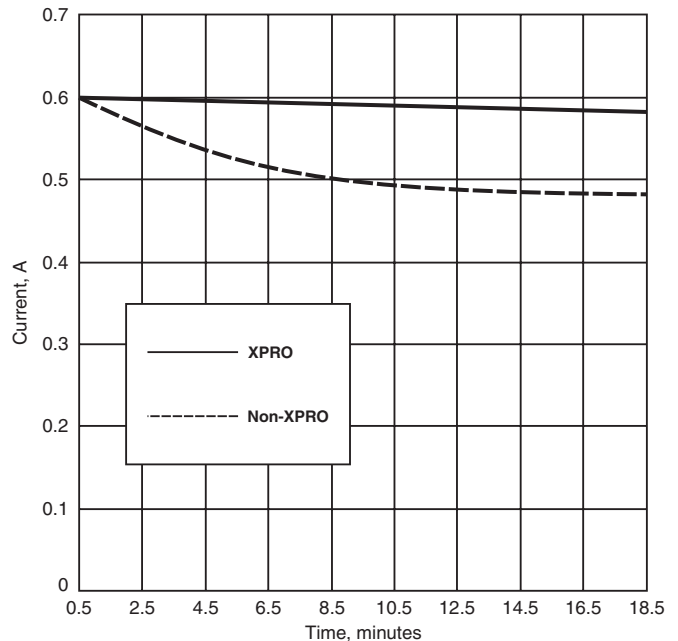

**Application**

For use with most proportional valves. GP, HP, JP, GTP and AP series valves.

**Dimensions** Millimeters (Inches)

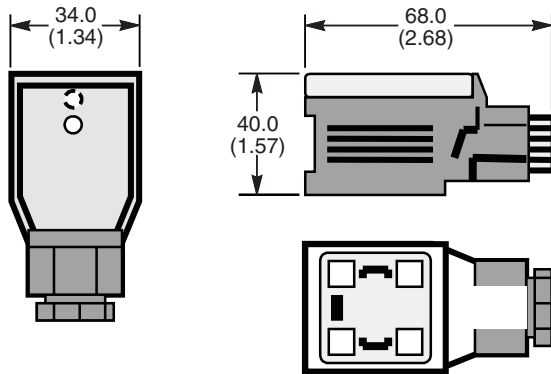

**Ordering Information**



Code	Maximum Current
902rid	1.6A
932rid	2.6A
904rid	1.0A
934rid	1.4A

Setting for standard:  
 Dither frequency: 110 HZ

**Connection Details**

**XPRO902rid and XPRO932rid**

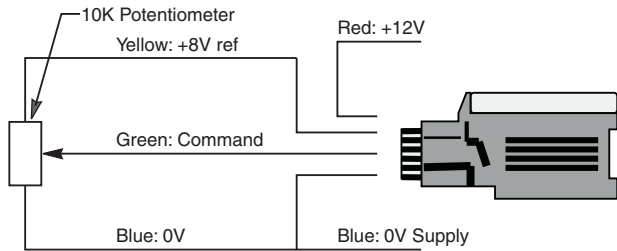

**XPRO904rid and XPRO934rid**

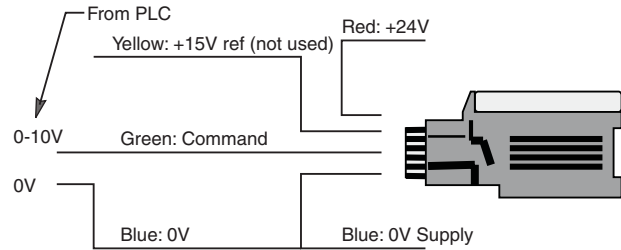
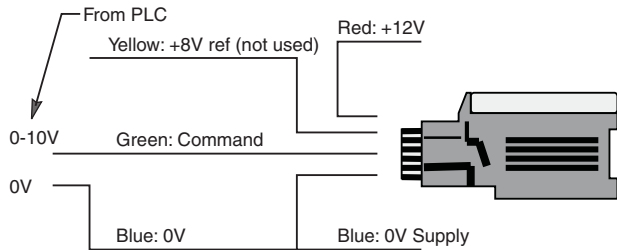
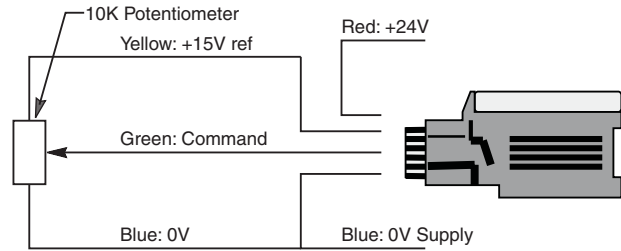

**Controller / Coil Combination**

Coil	Controller	
	XPRO 902rid	XPRO 932rid
CCS012D	X	
CCP012D	X	
CAS012D	X	
CAP012D		X

Coil	Controller	
	XPRO 904rid	XPRO 934rid
CCS024D	X	
CCP024D	X	
CAS024D	X	
CAP024D		X

- CV** Check Valves
- SH** Shuttle Valves
- LM** Load/Motor Controls
- FC** Flow Controls
- PC** Pressure Controls
- LE** Logic Elements
- DC** Directional Controls
- MV** Manual Valves
- SV** Solenoid Valves
- PV** Proportional Valves
- CE** Coils & Electronics
- BC** Bodies & Cavities
- TD** Technical Data

**Technical Information**

- CV** Check Valves
- SH** Shuttle Valves
- LM** Load/Motor Controls
- FC** Flow Controls
- PC** Pressure Controls
- LE** Logic Elements
- DC** Directional Controls
- MV** Manual Valves
- SV** Solenoid Valves
- PV** Proportional Valves
- CE** Coils & Electronics
- BC** Bodies & Cavities
- TD** Technical Data

**General Description**

Soft Start Valve Controller. 12 and 24 Volt PWM. For additional information see Technical Tips on pages CE1-CE2.

**Features**

- Self contained DIN PWM 'Plug Top'
- High impact resistant moulded ABS
- Supplied with approximately 1 meter of two color coded cables
- Can be used with 12V DC and 24V DC coils
- Fixed 1-second ramp upon engagement

**Operation**

The 704 is a soft start plug top PWM controller used for reducing the hydraulic pressure peaks produced when a hydraulic valve is operated. It can simply be used in place of a standard DIN connector.

**Output Voltage**

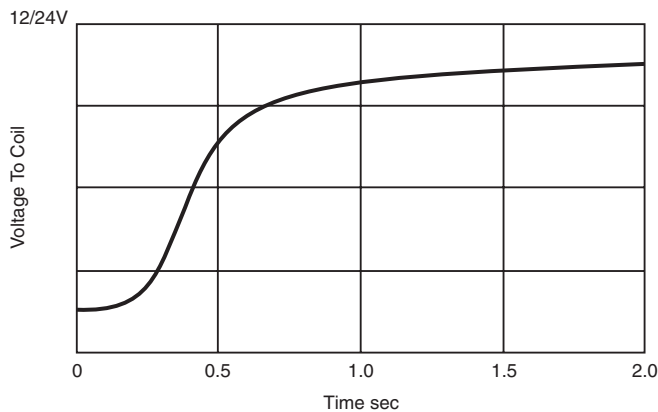

**Application**

For use with most proportional valves. GP, HP, JP, GTP and AP series valves.

**Specifications**

Nominal Voltage	12V DC and 24V DC
Maximum Power	36W
(IP) Rating	IP 65
Maximum Current	3.0A
Coil Resistance	4.5 - 30 ohms
Ramp Up	Fixed 1000ms

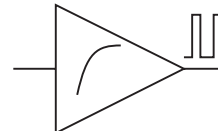
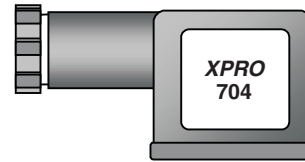

**Dimensions** Millimeters (Inches)

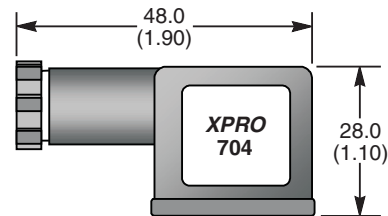

**Connection Details**

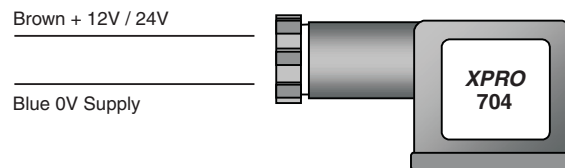

**Controller / Coil Combination**

XPRO 704 can be used with all 12V DC and 24V DC DIN coils.

**Ordering Information**

<b>XPRO</b>	<b>704</b>
Controller	Plug Type
<b>Code</b>	<b>Plug Type</b>
704	Soft Start



### General Description

Soft Start/Stop Valve Controller. 12 and 24 Volts, PWM with Adjustable Ramps. For additional information see Technical Tips on pages CE1-CE2.

### Features

- Adjustable ramp to engage and disengage
- Self contained DIN 'Plug Top'
- High impact resistant moulded ABS

### Operation

The 704b is a valve top mounted 'soft start, soft stop' controller for use with a range of valves.

The controller can be set to jump to a preset 'step' voltage then ramp up to maximum at a preset rate. It can also be set to jump down to a preset 'step' voltage and ramp down to zero. This can be used to eliminate 'bangs' or hydraulic shocks associated with operating a hydraulic valve.

### Output Voltage

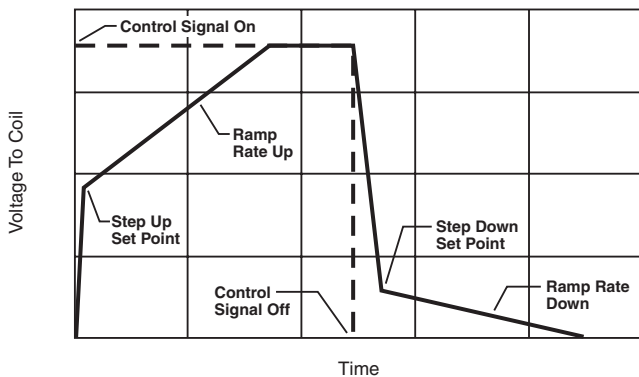

### Application

For use with most proportional valves. GP, HP, JP, GTP and AP series valves.

### Specifications

<b>Nominal Voltage</b>	12V DC and 24V DC
<b>Maximum Power</b>	36W
<b>(IP) Rating</b>	IP 65
<b>Maximum Current</b>	3.0A
<b>Coil Resistance</b>	4.8 - 30 ohms
<b>Coil Voltage</b>	+V Supply
<b>Control Resistance</b>	820 ohms
<b>Cable Length</b>	1 meter
<b>Step Up Adjust</b>	10 - 80%
<b>Step Down Adjust</b>	10 - 80%
<b>Ramp Up/Down</b>	200ms - 4s

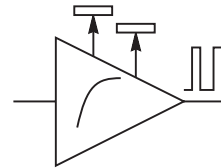
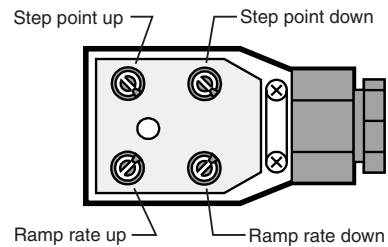

### Dimensions

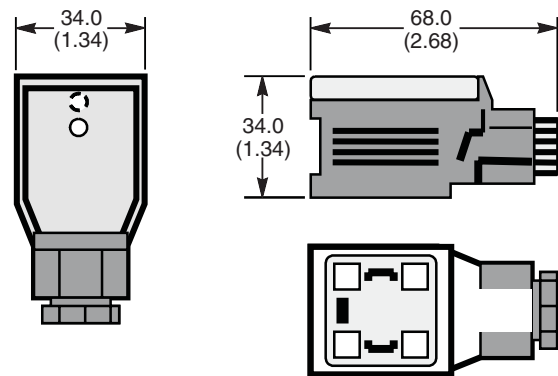

### Connection Details

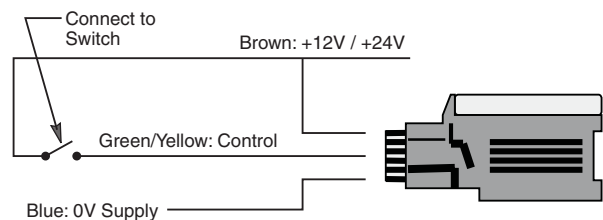

### Controller / Coil Combination

XPRO 704b can be used with all 12V DC and 24V DC DIN coils.

### Ordering Information

<b>XPRO</b>	<b>704b</b>
Controller	Plug Type
<b>Code</b>	<b>Plug Type</b>
704b	Soft Start, Soft Stop

**CV**

Check Valves

**SH**

Shuttle Valves

**LM**

Load/Motor Controls

**FC**

Flow Controls

**PC**

Pressure Controls

**LE**

Logic Elements

**DC**

Directional Controls

**MV**

Manual Valves

**SV**

Solenoid Valves

**PV**

Proportional Valves

**CE**

Coils & Electronics

**BC**

Bodies & Cavities

**TD**

Technical Data

**Technical Information**

- CV** Check Valves
- SH** Shuttle Valves
- LM** Load/Motor Controls
- FC** Flow Controls
- PC** Pressure Controls
- LE** Logic Elements
- DC** Directional Controls
- MV** Manual Valves
- SV** Solenoid Valves
- PV** Proportional Valves
- CE** Coils & Electronics
- BC** Bodies & Cavities
- TD** Technical Data

**General Description**

Power Saver Controller. 12 and 24 Volt, PWM. For additional information see Technical Tips on pages CE1-CE2.

**Features**

- Reduced power consumption and heat generation
- Self contained DIN 'Plug Top'
- High impact resistant moulded ABS
- Supplied with approximately 1 meter of two color coded cables

**Operation**

The 804 is a power saver plug top PWM controller used for reducing the current consumption of a standard on/off valve. The plug will deliver full voltage to the valve for 50mS then drop down to a holding voltage of 30% of the applied voltage. This can be used where multiple valves are used and power consumption is a consideration. It can simply be used in place of a standard DIN connector.

**Voltage Applied To Coil**

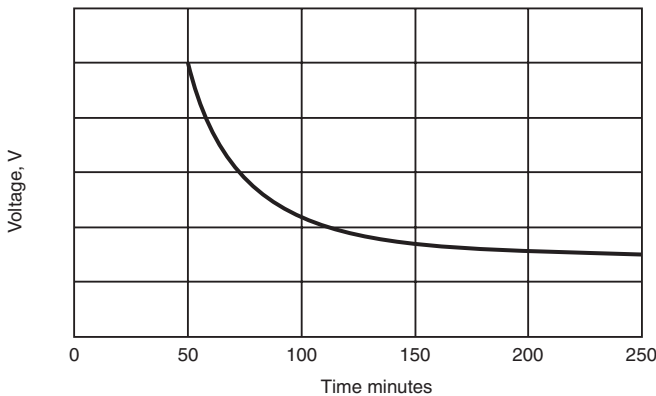

**Application**

For use with most on/off valves. GO, GS series valves.

**Specifications**

Nominal Voltage	12V DC and 24V DC
Maximum Power	36W
(IP) Rating	IP 65
Maximum Current	3.0A
Coil Resistance	4.5 - 30 ohms
Current Reduction	30% of Max

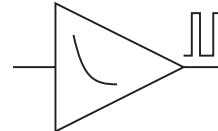
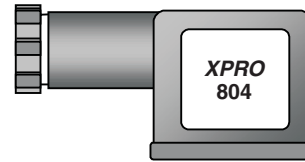

**Dimensions** Millimeters (Inches)

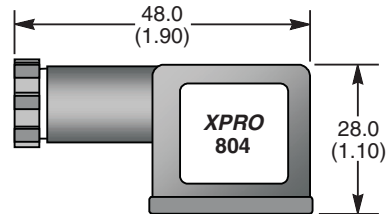

**Connection Details**

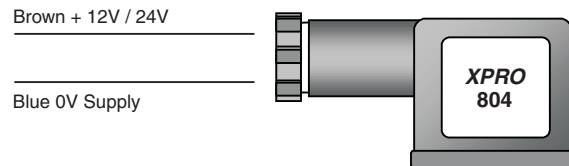

**Controller / Coil Combination**

XPRO 804 can be used with all 12V DC and 24V DC coils.

**Ordering Information**

<b>XPRO</b>	<b>804</b>
Controller	Plug Type
<b>Code</b>	<b>Plug Type</b>
<b>804</b>	Power Saver Plug

